



The SwingAway ('CEVNT') Bed Assembly Instructions

Issued 18/07/10, Hideaway Beds Ltd

Updated: 2/3/12, 15/05/12, 19/05/16, 13/07/17

By using this Assembly Guide, you hereby agree to the following:

Our own patent internationally protects all manufactured items. Your statutory rights as a consumer are not affected. Please note that we practice a policy of continual review and reserve the right to change the above guide at any time without notice. E&OE Hideaway Beds Ltd July 2017.

www.hideaway.co.uk T: 01752 511111 info@hideaway.co.uk

Unit 1, Bluewater Estate, Bell Close, Plympton, Devon, PL7 4JH

SwingAway Vertical Wall Bed Assembly Instructions

The SwingAway (CEVNT) systems are vertically mounted wall beds that stand alone on their own sub-frame, which must be fixed to the floor and wall. The bed can be mounted in a recess or cabinet using bi-folding doors, concealed using a curtain etc. or left on view. NOTE: Doors cannot be fixed to the base of a SwingAway Bed. The counter balanced mechanism is suitable for use with most standard sized mattresses. Maximum mattress depth is 8”.

Important

- If packaging is damaged, check bed frame for any damages and all components are present. If any items are missing contact your retailer immediately.
- Please take time to read these instructions fully before attempting assembly of the SwingAway wallbed.
- The SwingAway must be fixed to the floor and wall. Failure to do so could be dangerous!
- **Do not attempt to operate the bed prior to securely fixing in place.**

Tools Required

- 5mm & 4mm Allen Key
- 13mm & 10mm Spanner

Note: The bolts supplied have square shoulders, which are designed to pull into the round holes in the frame when tightened.

Component List (See Figs 1, 2 & 3 Attached)

- 1 X Bed Frame (In 2 Pieces) ‘A’ & ‘B’
- 2 X Bed Frame Joining Bars ‘C’ & ‘D’ (1X Additional Central Bar On Double Beds).
- 2 X Sprung Counterbalanced Units ‘E’ & ‘F’
- 2 X Wall Brackets ‘G’
- 2 X Sub-Frames ‘H’ & ‘I’
- 1 X Mattress Support Bar ‘J’ (X 2 On Double Beds)
- 1 X Automatic Leg Bar (In 2 Pieces) ‘K’ & ‘L’
- 1 X Pull Handle ‘N’
- 1 X Leg Section ‘M’
- 1 X Pack Of Nuts, Bolts And Washers
- 2 X Bedding Straps

Fig 1: Bed Sub-Frame Sub-Assembly

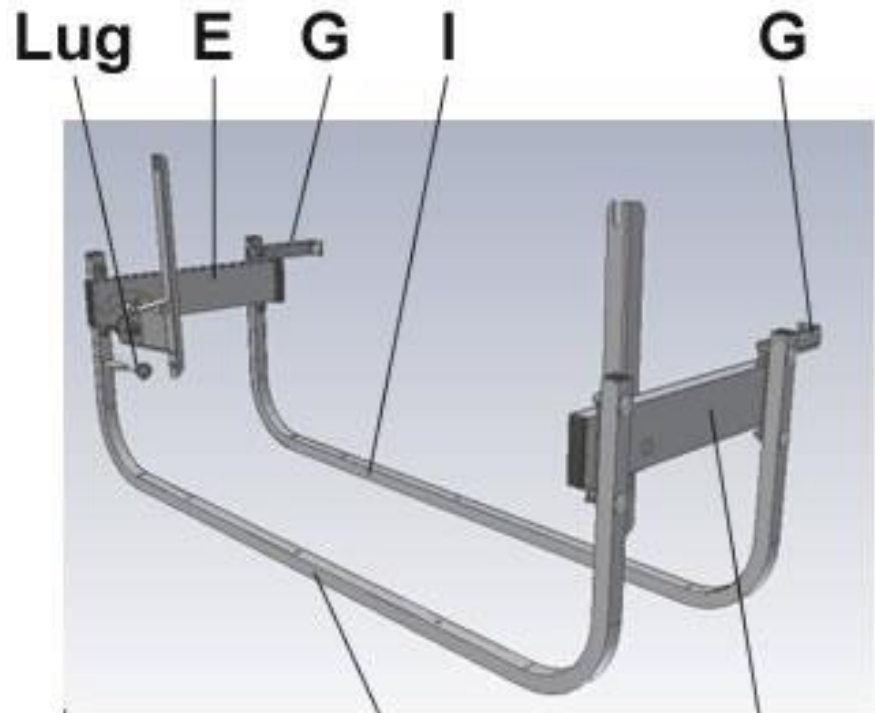

Fig 2: Bed Frame Sub-Assembly

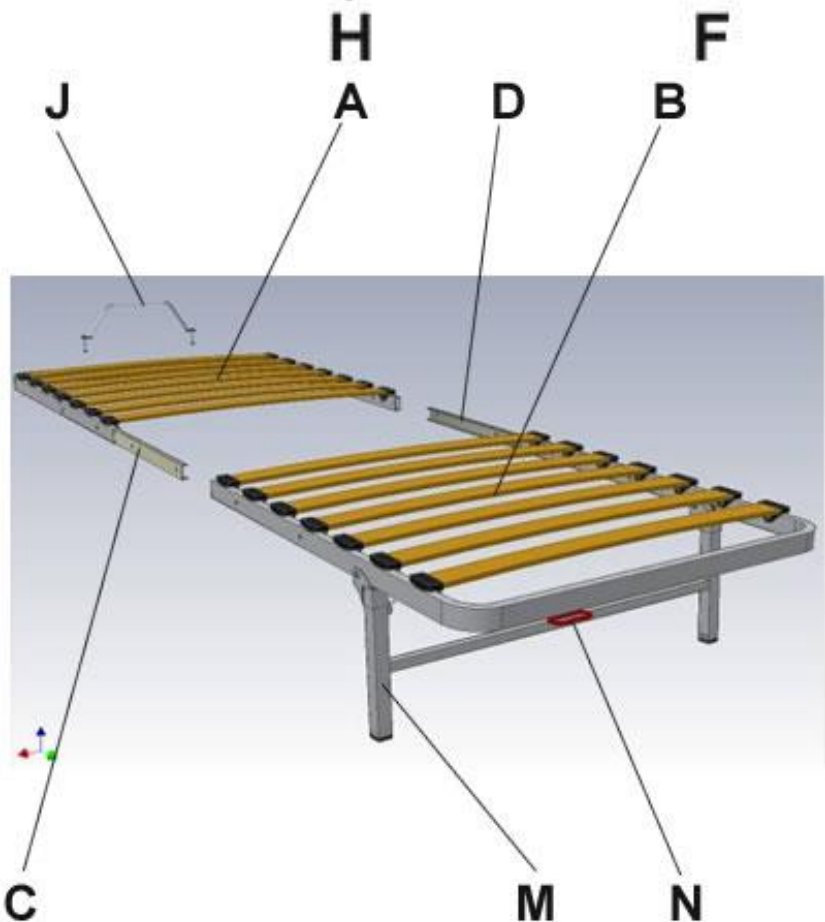

Fig 3: Bed Frame Complete Assembly

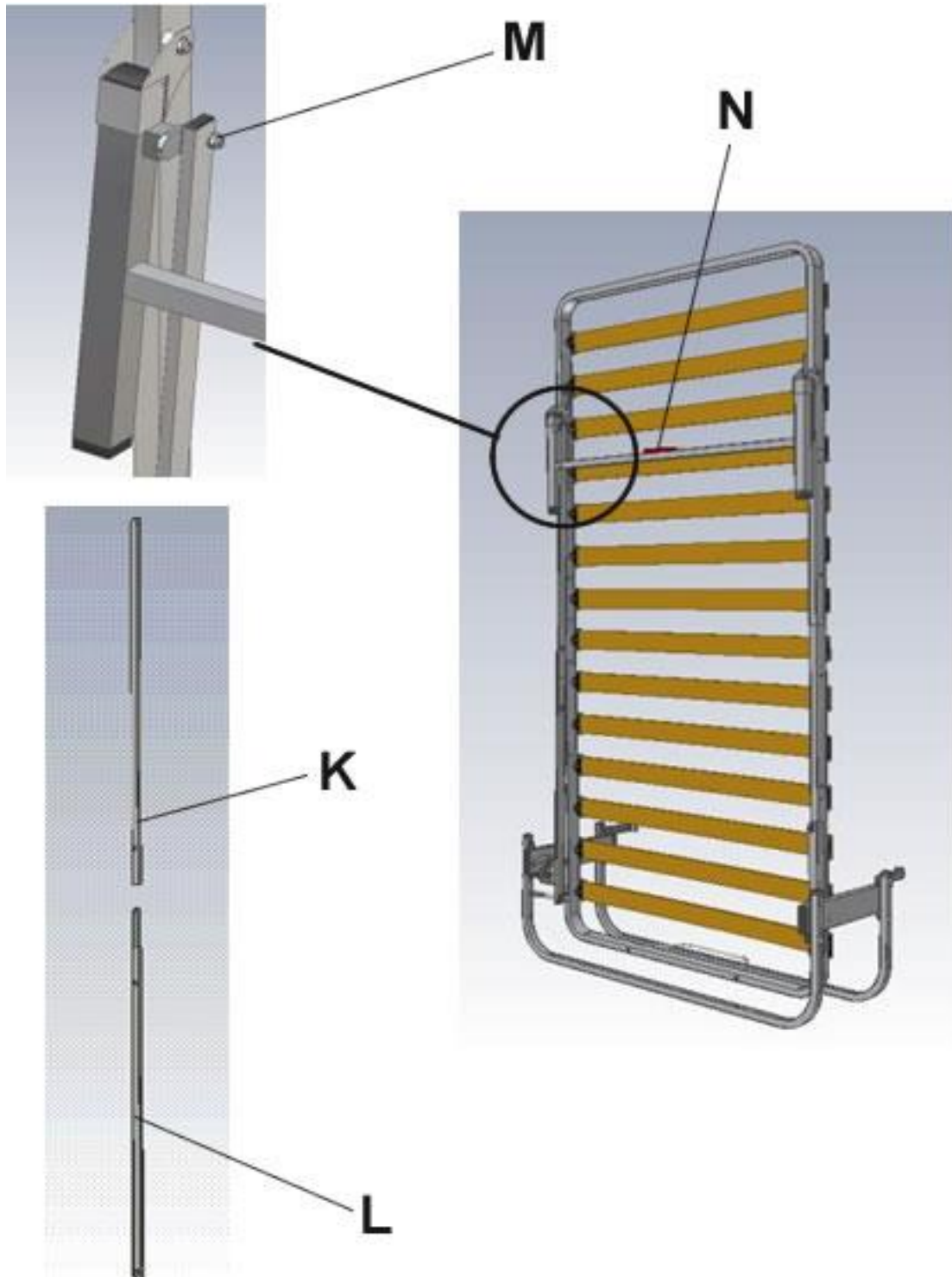
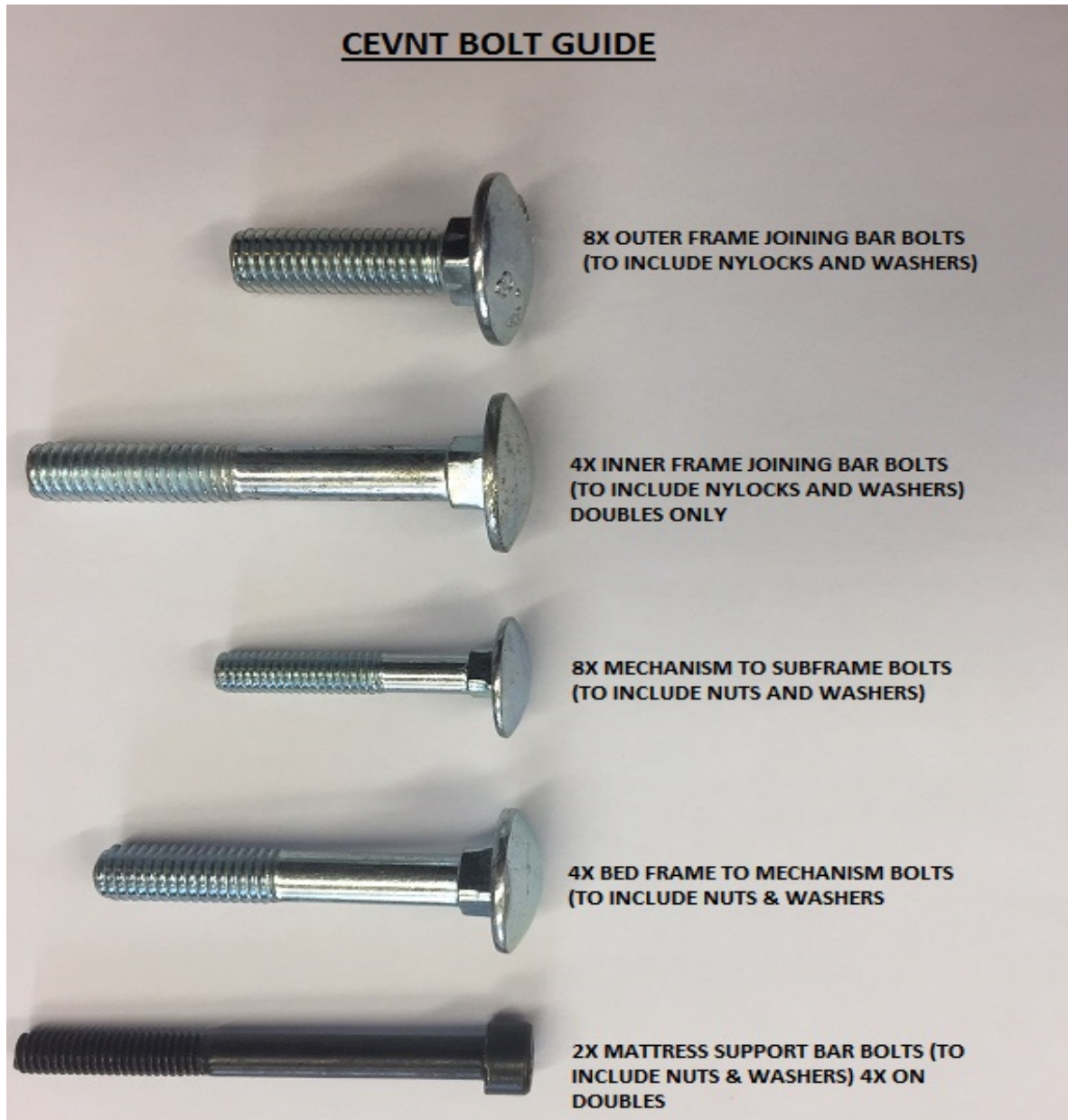

Fig 4: Bolt Guide



Assembly Instructions

Bed Frame Assembly (fig 2)

1. Slide the two joining bars C & D into the sides of the Bed frame A. Insert them until the two holes in the joining bars line up with the two holes in the bed frame (this may require some force, if necessary use a Nylon hammer). For double sizes, a central joining bar needs to be fitted at this time. Place bed joining bolts into these holes and secure hand tight with nuts.
2. Slide Bed Frame B over joining bars C & D until the holes in the joining bars and the holes in the frame are aligned then insert the final bed joining bolts. Now tighten all bolts. (fig 2)
3. Bolt the mattress support 'J' to the Head end of the bed frame. (fig 2)



Sub Frame Assembly (fig 1)

4. Assemble the sub frame as shown in fig 1. 'H' is the bar with the additional Lug; ensure that 'H' is located at the front and that the lug is on the left hand side of the assembly as in fig 1. Bolt the counterbalanced units 'E' & 'F' to the sub-frames 'H' & 'I' as shown in fig 1. Do not tighten the nuts yet.
5. Before tightening the nuts, mount the angled wall brackets 'G' to the top rear bolts on the sub-frame 'I'. The brackets have two holes; the ones to be used are determined by the thickness of the mattress which dictates the distance of the bed frame from the wall.

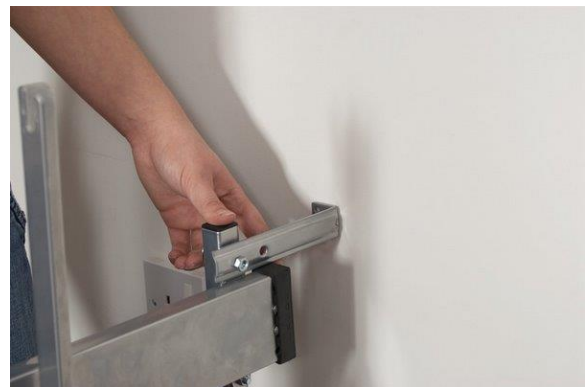

Complete Assembly (fig 3)

6. Place the bolts into the holes at the head end of the bed frame. Lift the bed frame into position, lining the bolts up with holes of the counterbalanced units. ('E' & 'F' in Fig 1) and securing by tightening the nuts.
7. Join together the two halves of the automatic leg bar 'K' & 'L' then attach the end with the smaller hole to leg 'M' (Fig 3).
8. Attach the end with the bigger hole to the lug on frame 'H' (Fig 1) using the washer and split pin. (Fig 3)
9. Screw pull handle 'N' to the crossbar of the legs (Fig 3). Place the assembled bed and sub-frame in the preferred position in the room and mark out the holes to be drilled in the wall and floor. Fix as appropriate. **NOTE: IT IS ESSENTIAL THAT THE BED ASSEMBLY IS SECURELY FIXED TO FLOOR AND WALL WITH CORRECT FIXINGS (NOT SUPPLIED).**
10. Fix the sub-frame securely to the wall using the correct fixings to suit the wall and floor material.
11. With the bed in the horizontal position, place the mattress onto the frame and secure with bedding straps. N.B. without the weight of the mattress the bed will try to return to its upright position, so it is suggested to have someone assist you by holding the bed whilst you put the mattress on.



Important Safety Factors

- **Do not attempt to operate the bed prior to securely fixing in place.**
- Due to the extremely reactive springs, it is important that you always manually control the bed by maintaining hand contact whilst in the ascent and decent position.
- Do not remove the mattress whilst in the horizontal position unless the frame is being held by another person.
- If you are relocating the bed do not remove any of the fixings unless the bed is in the vertical position.
- Children are discouraged from being in the vicinity when being assembled, fitted and from playing with the model either in the sleeping or stored position.
- Care must be taken when operating the bed, never lift the bed with anyone on the bed.
- All wall beds and cabinets must be securely fixed to the wall and fixations regularly checked.